

# ACRYLITE® extruded (FF)

## #1 Glazing

### This brief gives advice for:

- Applications
- Planning and Design
- Fabrication and Installation
- Maintenance
- Equipment and Materials Suppliers

### Applications

Glazing applications for ACRYLITE® extruded (FF):

- Interior partitions
- Exterior storm windows
- Room dividers
- Sun and wind screens
- Skylights
- Interior insulating windows
- Storm door windows
- Picture frames
- Fascia panels
- Dome structures

### Planning and Design

This section gives advice for:

- Available products
- Light Transmission
- Solar Energy Control
- Sound Transmission
- Thermal Conductivity
- Hardness and Rigidity
- Strength and Stresses
- Expansion and Contraction
- Compatibility

### Available Products

Sizes	Thicknesses	Standard Colors	Protective masking
Up to 96x120	.060" .500"	Colorless Trans. Bronze 7C49, 7C40, 7C24, White WM30, WM32, Transp. Grey 7C025, 7C026	Polyethylene film and latex paper

### Light Transmission

Colorless, smooth ACRYLITE® extruded (FF) acrylic sheet has glass's clarity and 92% light transmission. Colorless ACRYLITE® extruded (FF) is warranted for 30 years not to lose more than 3% of light transmission. Contact Evonik Cyro for a copy of the warranty

### Solar Energy Control

Transparent ACRYLITE® extruded (FF) colored sheets cut glare and solar energy transmission. These sheets are available in various densities, as shown below. The density range helps the architect designer, or homeowner to choose a color density providing adequate daylight without excess glare or solar heat.

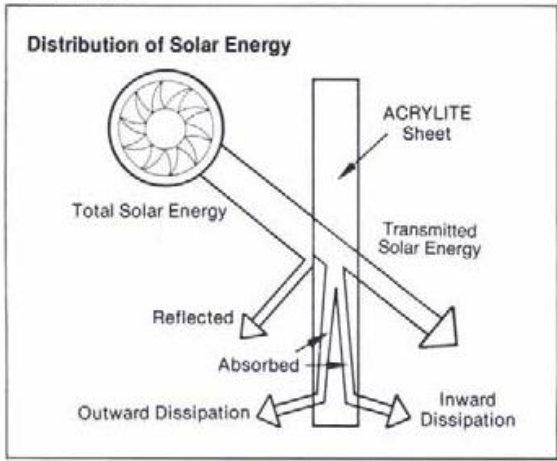

The table lists light and solar energy transmission percentages for transparent colors. Transparent colored ACRYLITE® extruded (FF) sheets transmit the same percentage of light though all thickness with the same color number (data for white sheets apply to 1/8" thickness only). As shown in the left column. The formula for shading coefficients is as follows:

Shading Coefficient = Solar heat gain of ACRYLITE® extruded (FF)/ Solar heat gain of 1/8" clear glass.

### Transmission of Transparent Colored ACRYLITE® extruded (FF) All Thicknesses\*

Color	Light Transmission	Solar Energy Transmission	Shading Coefficient
Colorless 0A000	92%	89%	.098
Bronze 8C030	10%	20%	.045
Bronze 7C049	27%	35%	.061
Bronze 7C024	45%	56%	0.76
Grey 7C026	12%	26%	0.61
Grey 7C025	29%	42%	0.72
White WT030	29%	34%	0.43
White WT031	47%	63%	0.74

\*White colors values listed for .125" thickness only.

### Sound Transmission

A barrier's sound reduction depends on its weight per square foot, surface area, rigidity, and air tightness. The latter is important—acrylic sheet with good sound reduction may not improve the performance of a non-airtight window.

In airtight surroundings, sound reduction increases with increased sheet thickness (wt. /sq. ft.) and decreases with increased area. Doubling the area increases transmission several decibels. Use the following values of sound pressure and loudness reduction for acrylic in airtight, resilient settings.

### Sound Reduction

ACRYLITE® extruded (FF) Sheet Thickness	Average Sound Transmission dB= Loss 100-3200 Hz	STC Rating
3mm	22	23
4,5mm	25	26
6mm	28	28
9.5mm	30	30

For more information refer to our Technical Bulletin "Sound Transmission Through ACRYLITE® Sheet".

### Thermal Conductivity

A material's thermal conductivity, or ability to conduct heat, is called the k-factor. This is an inherent property independent of thickness and surroundings.

The k-factor of ACRYLITE® extruded FF = 1.3 BTU/ (hr. (sq.ft) (°F/in. thick)

The k-factor is a physical property of a material.

The U-factor, or overall heat transmission coefficient, is the amount of heat which will pass through one square foot of a specific thickness of material per hour. This factor, expressed in BTUs, measures heat loss or gain through a window. U-factors depend on specific conditions (e.g., single or double glazing) and differ for summer and winter.

Listed below are U-factors for several thicknesses of ACRYLITE® extruded (FF) sheet for single-glazed, vertical installations, based on ASHRAE (American Society of Heating, Refrigeration, & Air-Conditioning Engineers) summer and winter design conditions.

### U-Factors—BTU/ (hour) (sq.ft.) °F

ACRYLITE® extruded Sheet Thickness	Summer Conditions	Winter Conditions
3mm	0.98	1.06
4mm	0.94	1.02
6mm	0.90	0.97
9.5mm	0.83	0.89

Total heat loss or gain through a window due to temperature differences expressed in BTUs/hr., – window area. sq. ft. x Indoor temp–outdoor temp) °F x U-factor (from above table). Include solar-radiated heat gain within a structure to find total heat gain.

ACRYLITE® extruded (FF) sheet insulates better than glass. When single-glazed, its U-factor is about 10% lower than that of equally thick glass. This material is also more resistant than glass to thermal shock and stresses caused by temperature differences between the opposite surfaces of a window.

#### Hardness and Rigidity

Handle and clean FF sheet carefully. Plastic surfaces aren't as hard as glass. FF sheet is less rigid than glass or metals but more rigid than such plastics as acetate, vinyl, or polyethylene. Under wind load, deflection causes acrylic to bow and foreshorten.

Consider maximum wind load and window size in selecting glazing panel thickness. Forming ACRYLITE® extruded (FF) sheet into ribbed or domed shapes improves rigidity and reduces deflection. Large, flat ACRYLITE® extruded (FF) sheets, if insufficiently supported, may deform permanently due to their weight or continuous loads such as snow. Increasing rigidity by forming minimizes cold flow.

#### Strength and Stresses

Though ACRYLITE® extruded (FF) sheet's tensile strength is 10,000 psi at room temperature (ASTM D 638), continuous loads below this value can cause crazing (numerous

tiny cracks in the material). Frames can create continuous loads—keep such loads below 1,500 psi. Avoid localized, concentrated stresses. For this reason, and due to thermal expansion and contraction, install 4'x4' or larger ACRYLITE® extruded (FF) sheets in frames—don't use screws or bolts.

#### Expansion and Contraction

Like most plastics, ACRYLITE® extruded (FF) sheet expands and contracts 3 to 8 times as much as glass or metals. Allow for size variation in frame systems and other fixtures. A 48" panel expands or contracts about 0.002" for each °F change in temperature. In outdoor use, where summer and winter temperatures differ as much as 100°F, a 48" sheet expands and contracts almost 1/4" (0.20"), or approximately ± 1/8" from mid temperature conditions. Calculate expansion and contraction allowances from your installing temperature measurements.

To figure expansion and contraction, use a constant, the thermal expansion coefficient. The value for acrylic is 0.00004 in. / (in.) (°F). Multiply panel length (inches) by the maximum possible temperature change and multiply the result by the coefficient. For example, if the temperature difference is 100°F (38°C) from winter night to noontime summer sun, an eight foot (96") acrylic sheet's length changes almost 3/8".

$$\begin{aligned} \text{Total Sheet Temperature} \\ \text{Movement} &= \text{Length} \times \text{Difference} \times \text{Coefficient} \\ &= 96 \text{ in.} \times 100^\circ\text{F} \times 0.00004 \\ &= 0.38 \text{ in.} \end{aligned}$$

For installation, expansion clearance = half total. Most installations occur in the mid-temperature range (55–75°F or 7–22°C). If you install outside this range, figure clearances using the above formula.

ACRYLITE® extruded (FF) absorbs water in high relative humidities, leading to expansion. At

relative humidities of 100%, 80%, and 60%, respective dimensional changes are 0.5%, 0.3% and 0.2%. A temperature and/or humidity difference on opposite sides of a sheet may cause slight bowing toward the higher value. As the differential lessens, the sheet resumes its original position

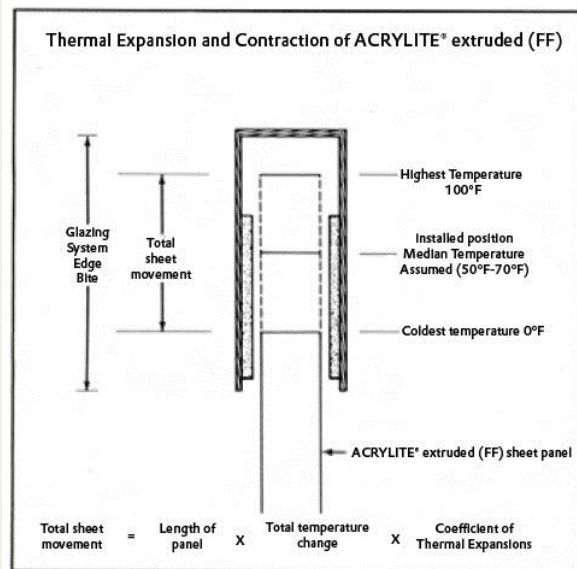

Dark-tinted ACRYLITE® extruded (FF) sheets (bronzes, grays excluding whites and ivories) with light transmission less than 60% and facing the south or southwest expand more than colorless sheet due to solar energy absorption. Movement of these panels is about 1.4 times that of colorless or lightly tinted sheet. For 96" (8 feet) of 131-2 Bronze (29% light transmission), it would be:

$$\begin{aligned} \text{Movement} &= \text{Length} \times \text{Difference} \times \text{Coefficient} \\ &= 96 \text{ in.} \times 100^\circ\text{F} \times 0.00004 \\ &= 0.38 \text{ in.} \end{aligned}$$

For dark-tinted sheet: movement = 0.38 in. x 1.4 = 0.53 in.

Use ACRYLITE® extruded (FF) sheets at temperatures from -30°F to + 190°F (-34°C to +88°C), depending on application. Don't exceed 160°F (61°C) in continuous service or 190°F (88°C) intermittently. All thermoplastics gradually lose tensile strength as the temperature exceeds 180°F

(82°C).

### Compatibility

ACRYLITE® extruded (FF) is manufactured from poly-methylmethacrylate, based on oil and natural gas. Some gasketing materials used with glass contain plasticizers (solvents). These can dissolve acrylic sheet, as can nail polish remover, paint thinner, or alcohol.

Evonik Cyro has tested gasketing products which may contact acrylic sheet for any potentially damaging material. These tests cover the products listed in the Equipment and Materials Suppliers section at the end of this brief. Forward questionable products to Evonik Cyro for testing. See the address and phone number for Technical Services at the end of this brief.

### Codes and Regulations

ACRYLITE® extruded (FF) sheet meets the requirements of:

- ANSI Z97.1 for use as a Safety Glazing Material in Buildings (for thicknesses equal to or greater than 0.080 inches)
- ANSI Z26.1 AS-4, 5, 6 & 7 for use as a Safety Glazing Material for Glazing Motor Vehicles.
- Federal Motor Vehicle Safety Standard 302: Flammability of Interior materials
- Federal Motor Vehicle Safety Standard 205: Safety Glazing
- Building Codes for use as a Light Transmitting Plastic:
  - New York City MEA # 145-80-M
  - ICC-ES Report
  - ESR-1260

Please contact Evonik Cyro Technical Center for more specific information.

### Fabrication and Installation

This section gives advice for:

- Handling and Storage
- Cutting by Scribing
- Interior Applications
- Exterior Applications

### Handling and Storage

Refer to Fabrication Tech Brief #1, Handling and Storage for storage recommendations or information about marking or removing masking, caring for ACRYLITE® extruded (FF) sheet, or removing scratches.

### Cutting by Scribing

Cut ACRYLITE® (FF) sheet up to 3/16" thick as you would cut. Don't remove masking. Use a Scriber— a scribing knife like the one pictured, a metal scriber, an awl, or a sturdy craft knife—to score the sheet. Draw the scriber several times (7 to 8 times for a 3/16"–thick piece) along a straight edge held firmly. Cut carefully using firm, even pressure. Continue each stroke cleanly off the sheet's edge.

Clamp the sheet or hold it rigidly under a straight edge with the scribe mark extending just beyond the table edge. Protect your hands with a cloth and wear safety glasses. Apply a sharp downward pressure to the sheet's overhanging edge—it'll break along the scribe mark. Scrape the edges to smooth sharp corners. Avoid this method for long breaks or material over 3/16" thick.

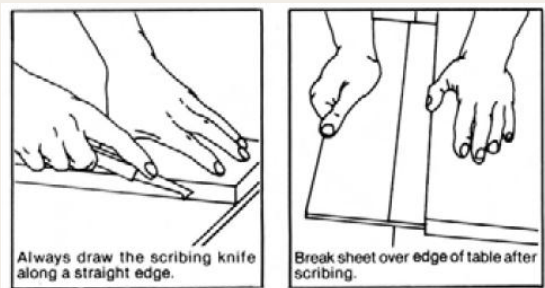

For more information, refer to Fabrication Tech Briefs #2, "Cutting with Circular Saws." and #3, "Other Methods of Cutting."

### Interior Applications—windows

Because interior applications are not exposed to wind pressure, you can use thinner sheets than normal for window cleaning.

Temperatures don't vary widely in interior applications, so provide half the expansion

allowances given for window glazing.

### Thickness for Outdoor Applications—30–40psf

Opening Size	Recommended Thickness
Up to 12 sq. ft	1/8"
12 to 32 sq. ft	3/13"

### Exterior Applications— general Recommendations.

- ACRYLITE® extruded (FF) sheet is not as rigid as glass. Follow the thickness recommendations below.
- ACRYLITE® sheet's expansion coefficient mandates clearances between the frame and the glazing panel. Cut panels shorter than the frame outside dimensions to provide the spaces listed in the table under "Exterior Expansion Clearances."
- Provide a channel or rabbet depth large enough to prevent the sheet withdrawing from the frame during high winds or cold weather. The rabbet must allow the sheet to expand in summer.
- Install the panel without bolting so it can expand or contract.
- Use sealant compounds and tapes flexible enough to accommodate thermal expansion and contraction. You can use mechanically held, approved gaskets such as EPDM, Santoprene® (a registered trademark of Monsanto Corp.), and Closed-cell Neoprene as sealing materials.

### Exterior Applications— thickness Recommendations

The thicknesses in the following drawing apply to rectangular windows with widths less than 3/4 their lengths installed vertically. For larger widths, use the next larger thickness. For long, narrow windows whose length exceeds four times their width, use the next smaller thickness

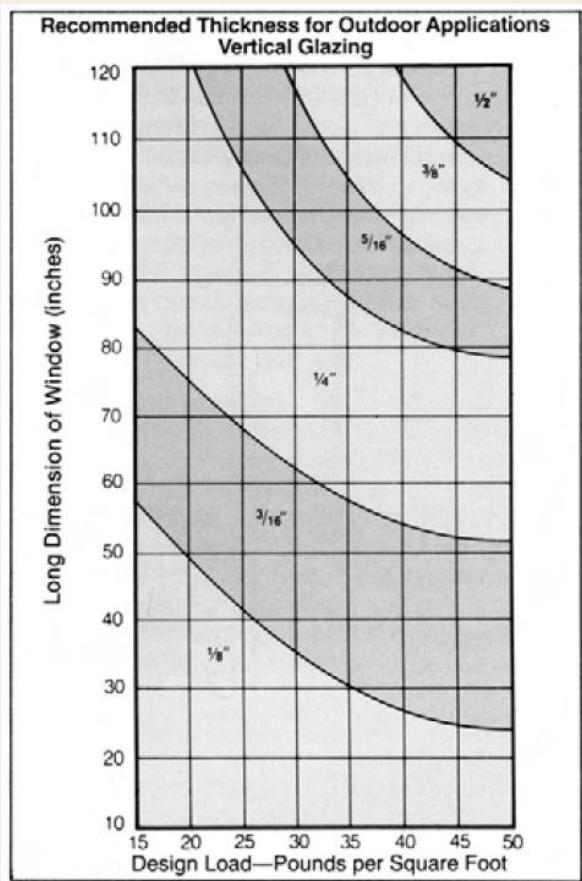

At a design load of 30 psi, glaze a 48"x 36" window with 3/16"-thick sheet. For a 76"x 48" opening, use 1/4"-thick sheet; for a 30"x 12" opening, specify 1/8"-thick sheet. Consult local building code offices for load requirements in your area. These thicknesses apply to vertically-installed windows only. If your installation is subject to a typical wind load above 30 psi, refer to the following table taken from the drawing above.

### Thickness for Outdoor Applications

Window Size	ACRYLITE® extruded sheet thickness
1-5 sq. ft	3mm
6-15 sq. ft	4.5mm
15-32 sq. ft	6mm
32-50 sq. ft	9.5mm

In most places, specify a design load of 25 to 40psf for windows up to 30 ft. above ground level. At low elevations, ground drag reduces wind velocity; thus, design one-story-building windows for lower wind pressures. As a rule, assume wind velocities from 100-120 mph equal design loads of 30 to 40 psi. The relationship between wind velocity and wind pressure.

$$P = 0.00256 \times V^2$$

In the equation, P = pressure in lb. /sq. ft. against a flat surface perpendicular to wind direction, and V= wind velocity in mph. In choosing design wind load, consider building height and safety.

### Exterior Expansion Clearances

The tables below are for installations in the mid-temperature range (55-75°F or 7-22°C). If you're installing in extreme temperatures or the installation is likely to encounter extreme humidity for long periods of time, use the formula for thermal expansion and contraction and humidity expansion in the example on page 3.

### Expansion clearances for Colorless Sheet (mid-Temp Range)

For Opening	Cut ACRYLITE® extruded sheet shorter outside frame dimension by:
Up to 36"	1/16"
36"-65"	1/8"
65"-90"	3/16"
90"-117"	1/4"
117-144"	5/16"

## Dark-Colored Sheet Expansion Clearances- Transmission 60% or less

For Opening	Cut ACRYLITE® extruded sheet shorter outside frame dimension by:
Up to 27"	1/16"
27-45"	1/8"
45"-63"	3/16"
63-82"	1/4"
82"-100"	5/16"
100"-117"	3/8"
117"-135"	7/16"
135"-144"	1/2"

For an opening of 48"x 72", cut colorless ACRYLITE® extruded sheet 47-7/8" x 71-13/16" and dark colored sheet 47-13/16" x 71-3/4".

### Sash Design and Rabbet Depth

You don't need rubber setting blocks under ACRYLITE® extruded (FF) sheets. If you use them, allow block and expansion space. Because of gravity, all vertical expansion or contraction may occur at the frame top. Make the top rabbet deep enough for total expansion and contraction.

The rabbet depths listed below allow for fore-shortening by wind deflection. Use standard extrusions if they meet requirements.

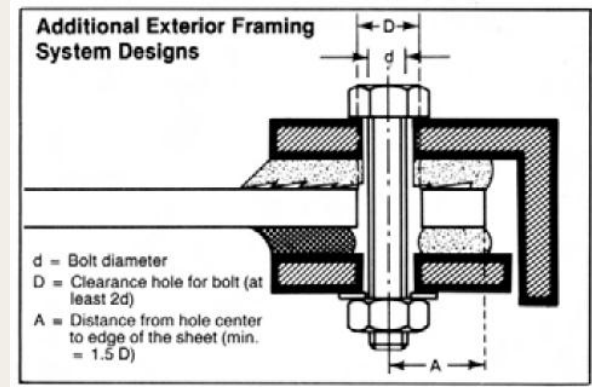
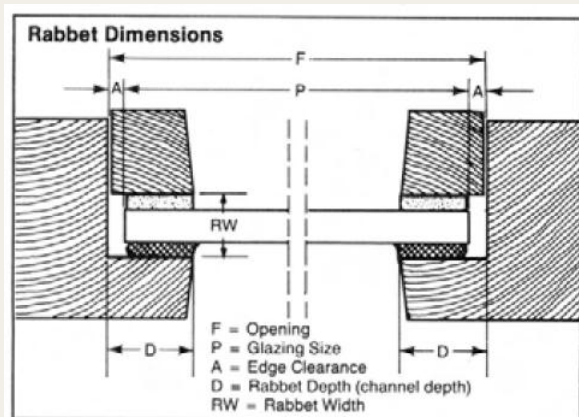

### Channel (Rabbet) Dimensions

Long Side of Panel	Minimum Rabbet Depth (D)	Minimum Rabbet Width (RW)
24"	7/16"	3/8"
36"	5/8"	3/8"
48"	3/4"	9/16"
60"	7/8"	11/16"
72"	7/8"	3/4"
84"	1"	3/4"
96"	1-1/8"	3/4"

\* Note: Rabbet width= thickness of ACRYLITE® extruded + space provided for both sealant beads. See drawing above.

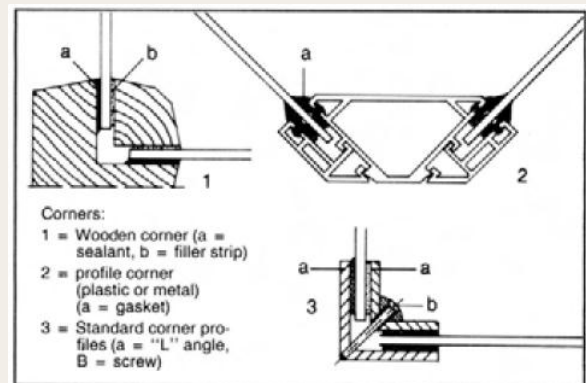

### Exterior Installation Instructions

NOTE: If there is any question about the compatibility of materials with ACRYLITE® extruded sheet, contact Evonik Cyro.

- Adjust. Plumb and square framing or sash.
- Remove rabbet projections to provide

uniform clearance and prevent point loads.

- Clean aluminum sash with VM&P naphtha to remove grease and protective finishes.
- Seal sash corners and intersections for a water tight sash. Prime-paint all sealing surfaces where necessary
- Measure opening precisely.

Figure expansion clearance from the Expansion Clearances tables above and deduct from the opening to determine cut sheet size. Cut to size accurately.

Remove protective masking before placing the panel in the sash, or roll back masking edges. Remove masking right after installation to prevent bake on by the sun.

### Exterior Glazing-Small Lights- Both Dimensions 24" or Less

- Thickness of ACRYLITE® extruded (FF) sheet can be 1/8".
- Frame: use wood, metal, or rigid PVC with 7/16" minimum rabbet depth.
- Clearance: cut the light 1/16" shorter than the opening, allowing expansion.
- Glazing Methods: Face glaze or channel glaze using approved elastic (no hardening silicone) glazing compound or butyl calk (for channel glazing only).

Apply enough glazing compound so it oozes out after you've pressed ACRYLITE® extruded (FF) sheet into the opening. Center the light in the sash, bed the removable stop in a face glazing design, or fill in the front edge of a channel glazing with compound.



### Glazing Intermediate and Large Lights Glazing Methods

For panel sizes up to 96"x 144", use continuous wood bead, metal stop, or channel glazing-not points or clips. Use elastomeric sealing compounds, vulcanized butyl tape, or dry gaskets as sealants. They work because they allow large panels' expansion and contraction without breaking weather seals. Don't use ordinary glazing compound

Be sure gunned in sealing beads are at least 1/4" wide by 1/4" deep. Set the 1/4" sealant bead by inserting a 1/4" continuous non-oily filler tape into the sash. If there's any question about a material's compatibility with ACRYLITE® extruded (FF) sheet, contact Evonik Cyro.

### Sealant Recommendations

Sheet Size	Recommended Sealant
Up to 36"x36"	<ol style="list-style-type: none"> <li>1. Gun grade acrylic latex calk allowing <math>\pm 15\%</math> movement</li> <li>2. Dry gaskets (EPDM, Santoprene®, or Closed-cell Neoprene)</li> </ol>
Up to 96"x96"	<ol style="list-style-type: none"> <li>1. High performance Silicone Polysulfide, or Polyurethane allowing <math>\pm 25\%</math> movement</li> <li>2. Dry gaskets (EPDM, Santoprene®, or Closed-cell Neoprene)</li> </ol>
Up to 96"x144"	<ol style="list-style-type: none"> <li>1. High performance Silicone Polysulfide, or Polyurethane allowing <math>\pm 50\%</math> movement</li> <li>2. Dry gaskets (EPDM, Santoprene®, or Closed-cell Neoprene)</li> </ol>

### Sealant Systems

These systems have been tested and work if properly installed. Contact manufacturers for limitations and recommendations. There are two types of system installations: elastomeric or butyl tape. Elastomers are gunnable elastic rubber-like substances including high-performance silicone sealants, polyurethane sealants, and high-



performance polysulfide sealants. Butyl tapes are synthetic rubber supplied in roll form.

Always specify a primerless system when using ACRYLITE® extruded (FF) sheet.

**Elastomeric System Installation**

- Place ACRYLITE® extruded (FF) sheet directly into the sash or on setting blocks. Attach a removable stop.
- Place the continuous non-oily filler tape in the channel to a depth of 1/4" or 3/8" below the sight line (top edge of sash). This depth should be equal to the required sealant depth shown below. Refer to dimension S in the following drawings:

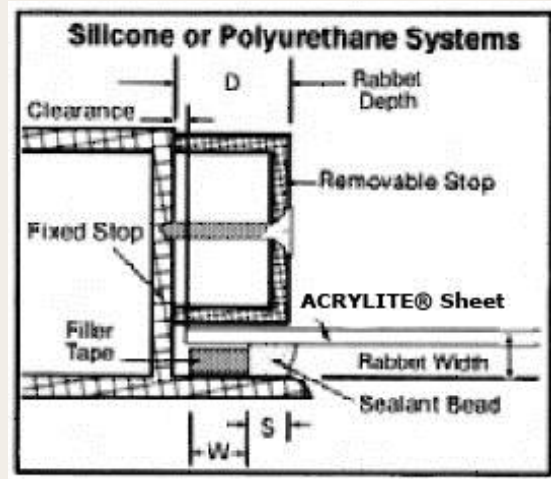

**Sealant and Filler Tape Dimensions for Large**

Thickness	Long Dimension	Polysulfide, Silicone, or Polyurethane Sealant Dimensions		Filler Tape Dimensions	
		Depth(S)	Width(T)	Depth(W)	Width(T)
3/16"	72-108"	1/4"	3/8"	3/4"	3/8"
1/4"	72-108"	1/4"	3/8"	3/4"	3/8"
1/4"	108-144"	1/4"	1/2"	7/8"	1/2"
3/8"	72-108"	1/4"	3/8"	3/4"	3/8"
3/8"	108-144"	1/4"	1/2"	7/8"	1/2"
1/2"	108-144"	1/4"	1/2"	7/8"	1/2"

If you use other filler materials such as neoprene foams, butyl foams or glazing tapes, contact manufacturers regarding compatibility with sealing compound.

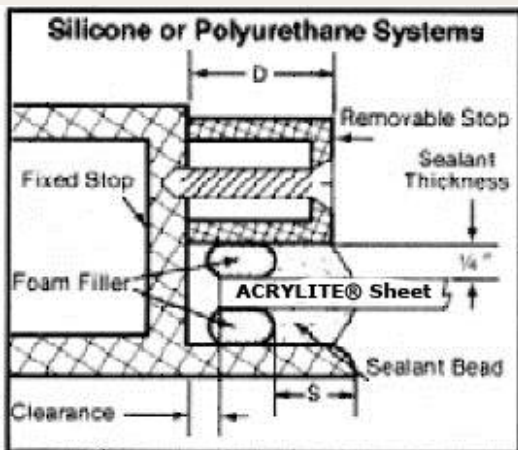
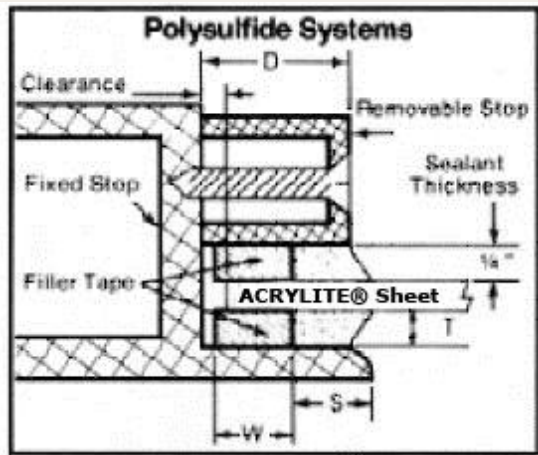

**Butyl Tape System Installation**

This system offers advantages the tape is pre-molded and fully cured; its seal performs well; you can install exterior and interior beads from the inside you needn't prime or clean. Coordinate channel, shim and tape dimensions—see the chart below under "Procedures." To work, the tape must be slightly compressed when the removable stop is in place.

**Butyl Tape and Spacer Dimensions**

Long Side of panel	Tape Width (TW)	Compressed Tape Thickness (TT)	Use Tape Size	Spacer Width(SP)
36"	3/8"	3/16"	1/4"	1/4"
48"	3/8"	3/16"	1/4"	3/8"
60"	3/8"	1/4"	5/16"	3/8"
72"	1/2"	1/4"	5/16"	3/8"
96"	1/2"	5/16"	3/8"	1/2"

## Procedures

- Adhere 1"-long spacer shims (SP) every 12" around the fixed stop's perimeter. Use at least two shims per edge. Shim thickness and width are critical. The following table has required dimensions. See the following drawing.
- Leave release paper in place. Apply butyl tape (TW) to the fixed stop on the sash's perimeter; position the tape 1/16" below the slight line (top edge of sash). Overlap the tape at least 1/8" at corners and splices.
- Remove release paper.
- Place the ACRYLITE® extruded (FF) sheet panel directly in the sill or on setting blocks. Center it in the sash and press firmly against the tape. Maintain correct head and jamb clearances.

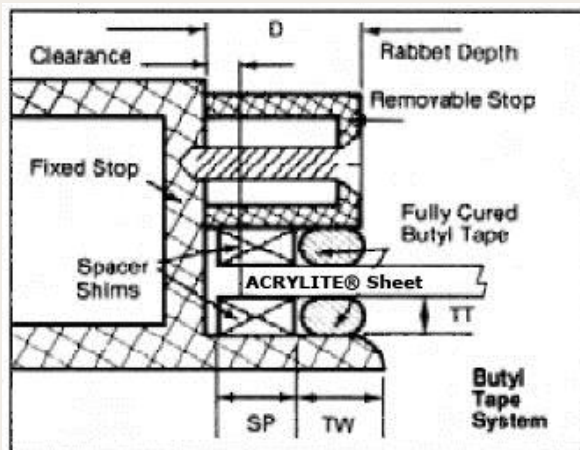

- Position spacer shims on removable stops opposite those on fixed stops.
- Apply butyl tape to removable stops and cut flush with the stops' ends. Remove release paper press stops in place and attach to the fixed stop.

The rabbet width must equal twice the final tape thickness (2xTT) plus the sheet thickness. See the Equipment and Materials Sources listing at the end of this brief for sources.

Provide a spacer shim 1/32" thinner than SP.

Compress butyl tape when removable stop is attached.

## Maintenance

Schedule acrylic glazing as almost the last step in a building's completion. Protect ACRYLITE® extruded (FF) sheet from paint, plaster, or tar splashes with suitable coverings such as drop cloths and from paint overspray using masking. Wipe off glazing compounds, sealants and paint smears while still soft with a clean, kerosene-moistened cloth.

Additional maintenance and handling advice is included in Fabrication Tech Brief #1, "Handling and Storage." Refer to that brief or contact Evonik Cyro's technical center for advice.

## Barrel Vault Construction

Attractive cold bent barrel vault skylights may be fabricated using ACRYLITE® extruded (FF) acrylic sheet with limitations. Only single glazing is recommended. Double glazing may result in excessive heat buildup between the panels. Ambient temperature may not exceed 160°F for continuous service.

Radius of curvature must equal or exceed 330 times the sheet thickness. Use only dry gasketing with a compatible glazing system. Sheet length must be 8' or less. The acrylic sheet must be free to expand and contract within the glazing system. Compression developed by the glazing system must be minimized by either positive spacing or applying a maximum of 30 inch pounds of torque on mounting fasteners on aluminum systems. Mill finish or light colored framing systems are recommended. Never use colorless sheet over tinted or colored sheet.

## Colored Framing Systems

Mill finish or light colored framing systems are recommended. Do not use dark colored systems for colorless acrylic sheet. These can lead to heat build-up which could damage the sheet.

#### Fire Precautions

ACRYLITE® sheet is a combustible thermoplastic. Precautions should be taken to protect this material from flames and high heat sources. ACRYLITE® sheet usually burns rapidly to completion if not extinguished. The products of combustion, if sufficient air is present, are carbon dioxide and water. However, in many fires sufficient air will not be available and toxic carbon monoxide will be formed, as it will when other common combustible materials are burned. We urge good judgement in the use of this versatile material and recommend that building codes be followed carefully to assure it is used properly.

#### Compatibility

Like other plastic materials, ACRYLITE® sheet is subject to crazing, cracking or discoloration if brought into contact with incompatible materials. These materials may include cleaners, polishes, adhesives, sealants, gasketing or packaging materials, cutting emulsions, etc. See the Tech Briefs in this series for more information, or contact your ACRYLITE® sheet Distributor for information on a specific product.

This information and all further technical advice is based on our present knowledge and experience. However, it implies no liability or other legal responsibility on our part, including with regard to existing third party intellectual property rights, especially patent rights. In particular, no warranty, whether expressed or implied, or guarantee of product properties in the legal sense is intended or implied. We reserve the right to make any changes according to technical progress or further developments. The customer is not released from the obligation to conduct careful inspection and testing of incoming goods. Performance of the product described herein should be verified by testing, which should be carried out only by qualified experts in the sole responsibility of a customer. Reference to trade names used by other companies is neither a recommendation, nor does it imply that similar products should be used.

Evonik Industries is a worldwide manufacturer of PMMA products sold under the ACRYLITE® trademark in the Americas and under the PLEXIGLAS® trademark in the European, Asian, African, and Australian continents. ©Evonik Cyro LLC. All rights reserved.

Printed in the USA.

Evonik Cyro LLC  
299 Jefferson Road, Parsippany, NJ 07054 US  
Phone +1800 631 5384  
[www.acrylite.net](http://www.acrylite.net) [www.acrylite-shop.com](http://www.acrylite-shop.com)