



SUNTUF[®] Plus

Corrugated Polycarbonate Sheet with Anti-Condensation

Greenhouse Installation Guide

Content

Introduction	2
Main Benefits	2
Profile Dimensions	2
Distance Between Purlins	3
Handling and Storage	3
Cutting	3
Drilling	4
Chemical Resistance - Compatible Adhesives & Sealants	4
Sealing	4
Use of Shading Compounds	5
Positioning the Sheets	5
Overlap	5
Arching Radius	6
Roof and Wall Fastener Location	6
Screws, Washers and Gaskets	6
Sheet to Sheet Stitching Fasteners	7
Additional Accessories	7
Standard Accessories for SUNTUF® Plus	8

Introduction

SUNTUF Plus has special benefits that allow it to give plants the best nurturing conditions. The sheet has a special built-in mechanism to prevent condensation drip. This feature allows SUNTUF Plus to transmit optimal levels of PAR light in any weather conditions and protect the crop in the greenhouse. SUNTUF Plus with the unique condensation control allows up to 30% light transmission increase at peak condensation periods. The condensation control feature is optionally offered on both sides for retractable greenhouse roofs. SUNTUF Plus maintain its superior mechanical properties for long periods of time. It sets the standard for efficient greenhouse roofing with over 25 million square meters installed in many greenhouses around the globe.

Main Benefits

- Up to 90% light transmission
- Eliminates condensation drip
- Retains its performance for many years
- Virtually unbreakable
- Blocks out UV and far IR radiation
- Available with 20% and 100% light diffusion
- Allows energy savings of up to 50%
- Flexible and easy to install
- Optional UV protection on both sides
- Wide service temperature range
- Available in 1260 mm and 1870 mm widths
- In cold climates: Reduces snow buildup in comparison with twin-wall
- 10 year limited warranty

Profile Dimensions

Width (mm)	Effective Width (mm)	Corrugations Pitch Distance (mm)	Number of Corrugations	Wave Overlap	Percent Overlap
1260	1210	76	17	1*	3.5
1870	1820	76	25	1*	2.5

* Two corrugations length overlap is recommended for slopes below 15%, or in case of extreme weather conditions (excessive rain and/or wind.)

Greca 76/18 Profile

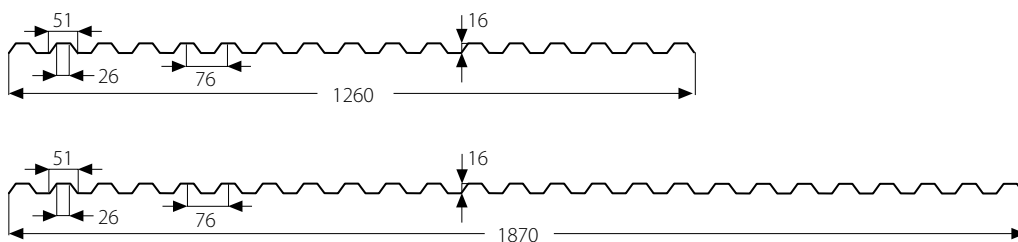

Omega 76/15 Profile

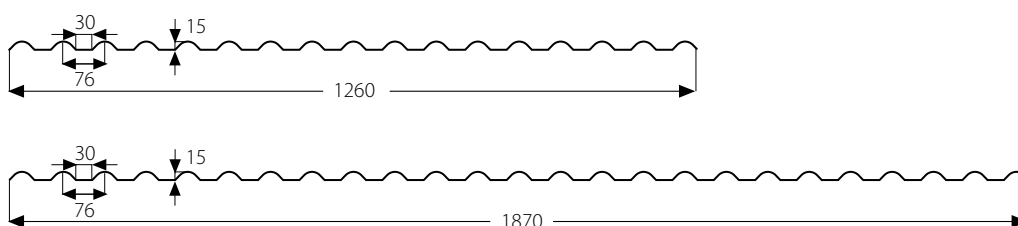

Distance Between Purlins

Profile	Sheet Thickness (mm)	Theoretical Weight (Kg/m ²)	Load (Kg/m ²)	Distance Between Roof Purlins (mm)	Distance Between Wall Purlins (mm)
Greca/Trapeze 76/18	0.8	1.20	90	1200	1200
			120	1100	
Omega 76/15	0.8	1.15	150	1000	

- 1.The dimensions depicted above do not supersede the requirements of local construction codes. The distances depicted above were calculated based on the structural properties with the following factors being taken into consideration: sheet deflection, potential wind load, potential snow load, hail and application load according to usual construction practice.
- 2.When designing a new roof, it is strongly recommended that the slope be above 10% (5.7°). (Consult your local Palram representative when recovering an existing greenhouse whose slope is shallower than this value).
- 3.The recommended maximum panel length is 7.0 m. The recommended maximum distance between the edge and first purlin is 900 mm or the value dictated by the design engineer. (See drawing on page 4, Figure 8b).
Wall purlins distance can be increased by 10% of roof recommendation.

Calculate the number of sheets as follows:

1. Divide the length of the roof (the length of the gutter) by the effective width of the sheet.
2. Calculate the required length of the sheet (to be no greater than 7.0m) according to purlin to purlin distance, plus the required extension beyond first and last purlin and overlap distance, if exists.

Handling and Storage

- 1.Palram corrugated sheets must be transported and stored horizontally on a flat, sturdy pallet whose dimensions are equal to or larger than the sheets themselves. The sheets should be secured and fastened to the pallet. It is possible to store sheets of smaller dimensions on top of larger sheets of the same type. (Never store sheets of larger dimensions on top of smaller sheets!) SUNTUF Plus must be stored in a cool and shaded location.
- 2.Important: Never cover the pallet with, or place on the pallet, materials that are good conductors of heat (e.g. Metal, pipes, clear or dark objects).
- 3.In cases where it is necessary to store the pallet outdoors, cover it with a white opaque polyethylene sheet, card board, or any other material that does not absorb or conduct heat. The total pallet must be covered.

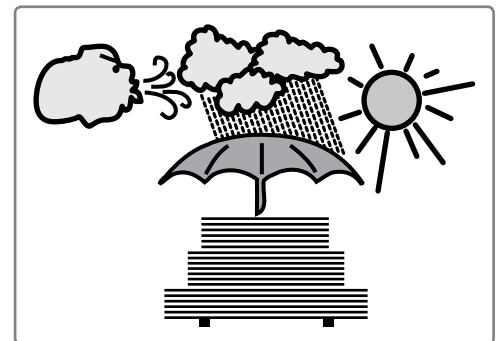

Cutting

It is possible to cut SUNTUF Plus corrugated sheets using a circular saw with small teeth, rotating at a high speed, taking care to advance the saw slowly. It is also possible to use a portable electric saw (Jig Saw) or sheet metal shears. In any case, it is important to support the sheet in the vicinity of the cut and clean away the dust and debris generated by cutting.

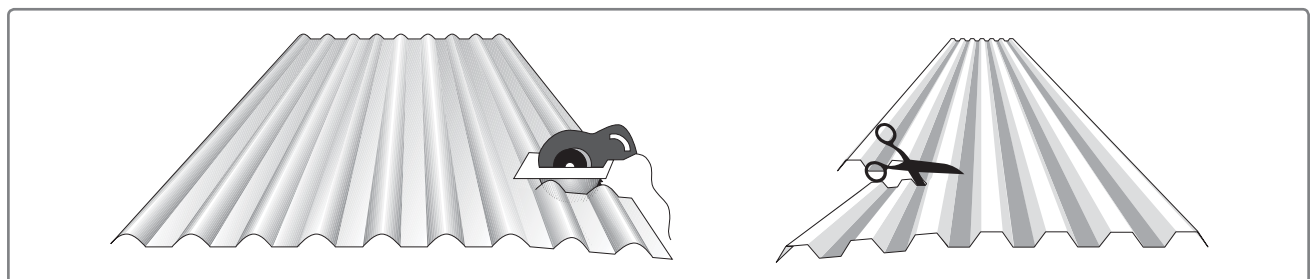

Drilling

1. Drilling should be carried out with a drill bit intended for metal. The hole diameter must be 4 mm larger than the diameter of the screw to be used. It is important to support the sheet in the vicinity where the sheet is being drilled. The dust generated by drilling must be cleared away before the insertion of the screw.
2. Special attention should be given to drill all the required holes perpendicular to the face of the material.

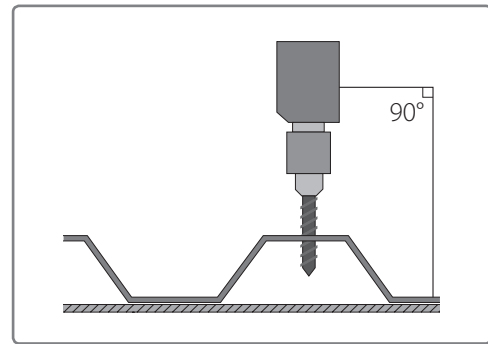

Chemical Resistance - Compatible Sealants and Adhesives

1. SUNTUF Plus sheets are resistant to a variety of chemicals and exhibit limited resistance to a second group of chemicals. A third group of chemicals will attack and cause damage to the sheet. The degree of damage will depend on the severity of attack and time of exposure.
2. Choose only sealants and adhesives which are compatible with SUNTUF Plus (see paragraph G).
3. Beware of installing the sheets on wet paint, or other incompatible materials, which may damage the polycarbonate sheets.
4. Use of sealants or adhesives not included in the recommended list must receive the Manufacturer's explicit approval. This can be obtained through your distributor. Use of materials not on the list, or which have not received the Manufacturer's explicit approval, may harm the sheet and will void all warranties and any responsibility of the manufacturer for the performance of SUNTUF Plus.
5. Your local distributor can provide additional information and forward materials for evaluation of their comparability with SUNTUF Plus.

Sealing

1. Compatible silicone sealants recommended for use with Palram polycarbonate sheets:

Manufacturer	Sealant
Soudal	MS Clear
Bison	Polymax

For information on alternatives, please consult your Palram distributor.

2. Shaped foamed Polyethylene closure strip should be used to prevent the entry of water, wind, insects or other small animals between installed sheets. A seal between the sheet and the edge purlin of the roof can be created using a sealing strip in the form of the profile. It is held in place by the same screw used to fasten the sheet to the purlin. The sealing strip should be manufactured from cross-linked polyethylene foam (XPE).

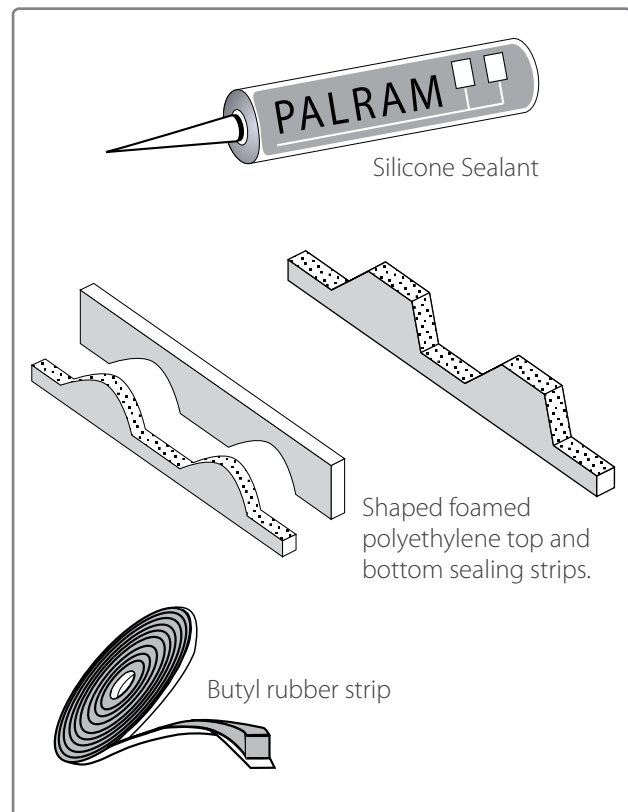

- Butyl rubber sealing strip should be used where the pitch is less than 15% or in case where penetration of wind or fumes must be prevented. The strip should be placed between the sheets at the width end lap, along and exteriorly to the screw line.

Warning: Do not use materials which are not recommended by Palram. Specifically, polyurethane foam should not be used as insulating foam with SUNTUF Plus. Contact with this material will render the sheets fragile. When in doubt, consult your Palram distributor.

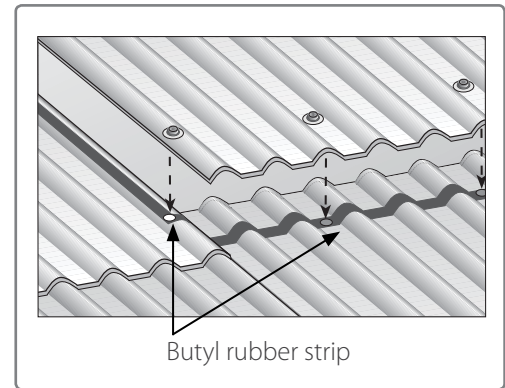

Use of Shading Compounds

- It is possible to apply shading compounds on SUNTUF Plus sheets.
- Use only recognized commercial brands, confirmed to be compatible with polycarbonate. Do not apply dubious mixtures that may contain incompatible components, which will attack and damage the sheets.
- In case of doubt, consult your SUNTUF Plus distributor, who can advise you on the proper use of shading compounds.
- You can ask for recommendations on compatible formulations that were tested and confirmed for use by Palram Industries. Note that all the recommended formulations are water-soluble and will eventually be washed away by rains.
- Shading compounds should be easily removed using a strong water jet in conjunction with vigorous brushing with a soft bristle brush, or wiping with soft cotton rags.

Positioning the Sheets

- Only one side of a SUNTUF Plus sheet is UV protected*. This side must always face out toward the sun. The UV protected side is indicated by a sticker or polyethylene strip along the length of the sheet. The sticker or polyethylene strip must be removed immediately after the sheet is installed.
- The sheets should be laid down on the roof or set upon the wall against the primary direction of wind and rain.
- Do not step on the panels between purlins.
- Stepping ladders and other devices required for safe work should be used.
- Never leave panels unattended until all the required screws have been tightened.
- Due to the sheets' low weight, SUNTUF Plus can be rolled for the purpose of lifting them to the roof. The sheets must be rolled perpendicular to the length of the corrugations, with the upper UV protected side facing outwards and the lower side with the anti-condensation treatment facing inward.

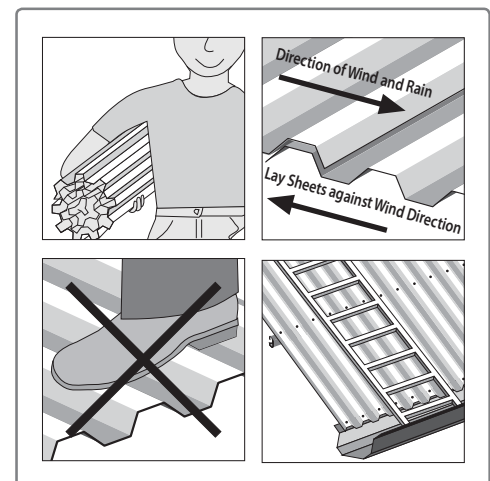

* Except for SUNTUF Plus UV2 which is manufactured with co-extruded UV protection on both sided when a special order has been placed.

Overlap

- Width overlap (sheet edge):
Minimum overlap: 120 mm
Minimum distance of 60 mm of each sheet's edge from center line of supporting purlins (line of screws).
Maximum overlap: 200 mm
- Length overlap: One corrugation**
- Roof Edge: Sheets at the roof's edge should extend beyond over the edge support by not more than 100 mm.

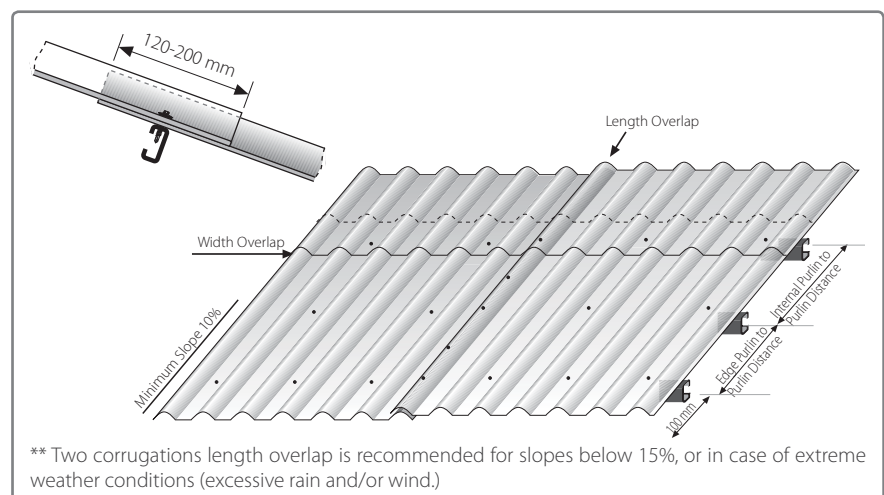

Arching Radius

When covering curved structures, it is possible to set the sheets on an arched framework so that they will arch within the range of elasticity of the sheets without inducing stress. The minimum radius of the arch created is 3.00 m for Omega and 4.00 m for Greca.

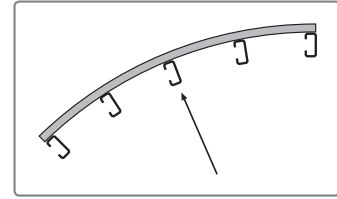

Roof and Wall Fastener Location

1. A fastening screw should be inserted into at least every third corrugation valley at each internal purlin.
2. Along the edge purlin, the screws are to be inserted into alternate corrugation valleys.
3. Along the length overlap, the screws are to be inserted into the overlapping corrugation crest on top of each purlin.
4. A hole must be pre-drilled into each screw location. The diameter of the hole must be 4 mm larger than that of the screw.
5. The screws should be tightened with an electric screwdriver with an adjustable clutch, taking care not to over-tighten. Excessive tightening may harm the sheet and cause premature failure.
6. Sheet-to-sheet stitching fasteners are recommended along the length of overlapping corrugations between the purlins, at least 2 units at every span (See "Sheet-to-sheet stitching fasteners", Page 7).

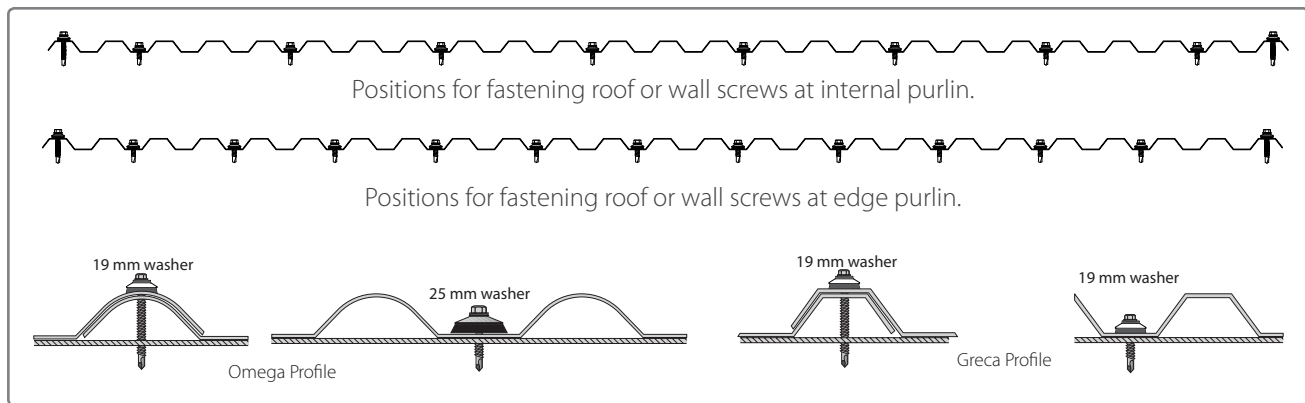

Screws, Washers and Gaskets

1. General Recommendations: For optimal long-term maintenance free service, Palram strongly recommends the use of heavy-duty corrosion resistant screws, and special metal washers with profiled 4 mm (at least) thick EPDM rubber gaskets*, 19 mm (crest) or 25 mm (valley) diameter (in Greca profile both crest and valley with 19 mm), to fasten the sheets to the supporting structure and seal the fastener's hole (Figure 1).
2. Use of self-tapping screws with pre-drilled holes or self-drilling screws is recommended. For wooden purlins, a special wood-screw should be used (Figure 2).
3. The screw placed into corrugation crest should be 6.3 x 38 mm (1/4 x 1 1/2 in.) or a #12 or 14 gage screw. Screws placed in a corrugation valley should be 6.3 x 25 mm (1/4 x 1 in.). Each screw should be fitted with a conical corrosion resistant metal washer at least 1 mm (0.04 in.) thick and a special EPDM gasket. The screw should be tightened moderately without deforming the washer and rubber gasket or distorting the corrugation.
4. Special attention should be given to the insertion of the screws perpendicular to the material face. Oblique insertion could damage the sheet and/or result in leaks (Figure 2).

* Palram offers to supply, upon demand, the recommended fastener combinations mentioned above, along with the SUNTUF Plus sheets.

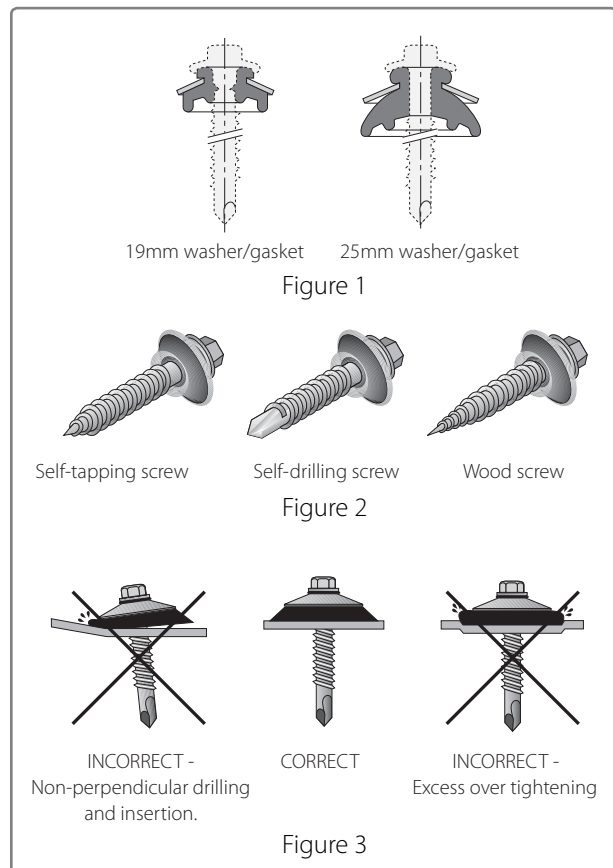

Sheet-to-Sheet Stitching Fasteners

Side-lap profiles

Top and bottom pre-drilled metal side-lap profiles are recommended for improved tightening of lapping sheets, between purlins, with $\frac{1}{4}$ " x 1" self-tapping screws every 400 mm and $\frac{1}{4}$ " x 2" self-drilling screws above each purlin.

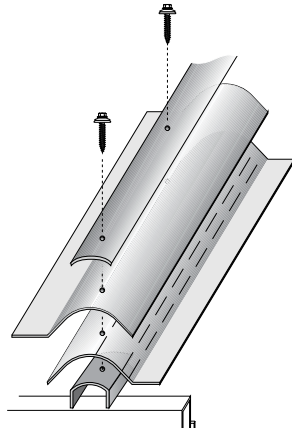

Stitching Fasteners

Stitching Fasteners: It is possible to use $\frac{1}{4}$ " x $\frac{3}{4}$ " self-tapping screws every 400 mm at the side-lap crest top for stitching the lapping sheets.

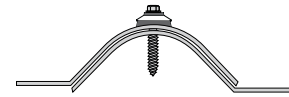

Sheet-to-sheet fastening screw between overlapping corrugations (detail), for Greca profile.

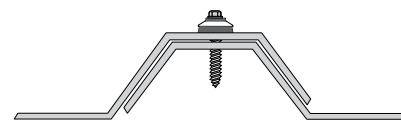

Sheet-to-sheet fastening screw between overlapping corrugations (detail), for Omega profile.

Additional Accessories

1. Omega Purlins: Palram recommends building the greenhouse utilizing special Omega shaped purlins to prevent condensation drips from the purlins. Care must be taken to collect the condensation water at the edge of the purlins.

Fastening Metal Profile: it is possible to install a special sheet metal angle profile for tightening the roof sheets along the purlins. The profile will be 30 x 40mm, 2mm thick.

Fastening distance – no more than 1200 mm.

Special care must be taken to fasten the angel profile on top of the Side-lap/mid crests, without over tightening, to avoid distorting the corrugations.

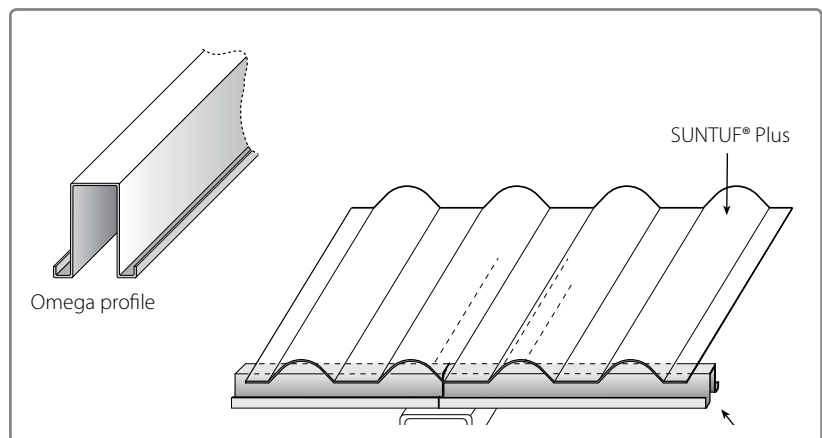

2. Corner / Side Ridge Closure: Two adjoining galvanized sheet-metal covering profiles (flashings) are used for closing the cladding sheets where the roof meets the gable wall, or a vertical closure between two walls corner.

a) the internal 100x100x1.5 mm profile is used to attach both edges of the cladding sheets to the structure.

b) the external 150x150x0.6 mm flashing profile will fasten to the internal profile through the cladding sheets and will close the gap between them, at the corner.

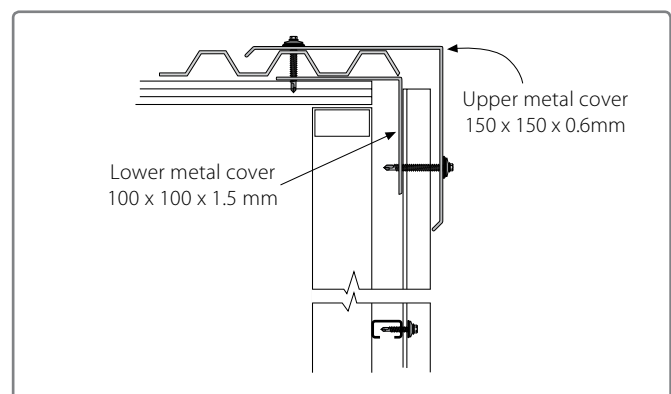

Standard SUNTUF® Plus Accessories

All items below can be purchased from Palram Industries and its distributors.

Universal Ridge Cap - Greca Profile

(Omega Profile Universal Ridge Cap is also available)

Dimensions: 1270 x 150 x 150 mm

1270 x 270 x 270 mm

Number of Corrugations: 17

Net Length: 1210 mm

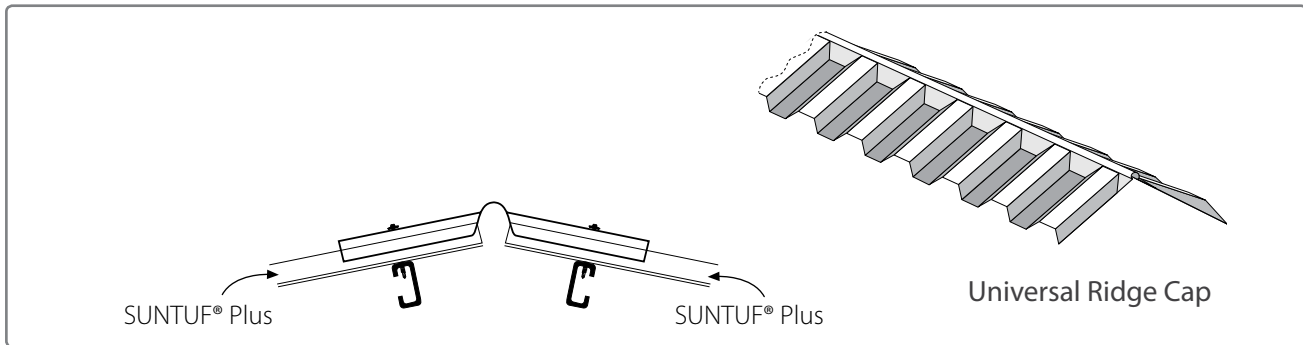

Flat Ridge Cap 150°

Dimensions:

2500 x 210 x 210 mm

Net Length: 2400 mm

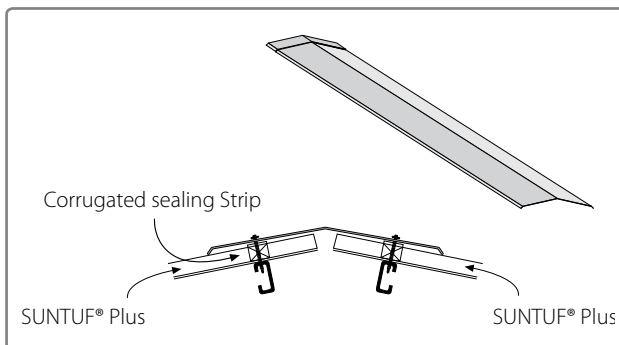

Flat Side Ridge - 90°

Dimensions:

2500 x 160 x 160 mm

Net Length: 2400 mm

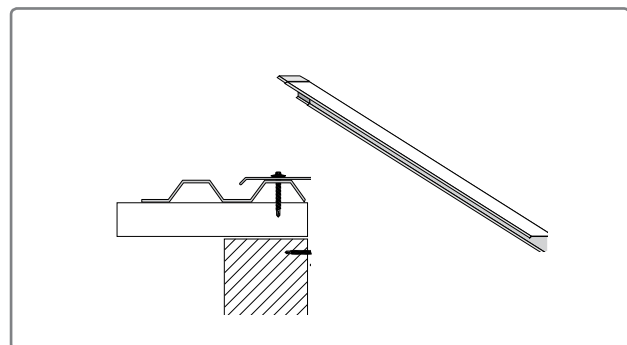

All marketing materials and any content therewith provided by palram® are provided solely for the purpose of supporting and enhancing the marketing of Palram® products. These materials are protected by Palram's intellectual property rights and may not be used for any other purpose or in connection with the sale of products of any other manufacturer. These materials may not be transferred to or used by any third party without prior permission of Palram.



PALRAM H.Q.

Tel: +972 4 8459900
Fax: +972 4 8444012
palram@palram.com
www.palram.com

PALRAM EUROPE LTD.

Tel: +44 1302 380777
Fax: +44 1302 380778
sales.europe@palram.com
www.palram.com

PALRAM AMERICAS

Tel: 610 2859918
Fax: 610 2859928
palramamericas@palram.com
www.palramamericas.com



61326 - 06.2011

In as much as Palram Industries has no control over the use to which others may put the material, it does not guarantee that the same results as those described herein will be obtained. Each user of the material should make his own tests to determine the material's suitability for his own particular use. Statements concerning possible or suggested uses of the materials described herein are not to be construed as constituting a license under any Palram Industries patent covering such use or as recommendations for use of such materials in the infringement of any patent. Palram Industries or its distributors cannot be held responsible for any losses incurred through incorrect installation of the material. In accordance with our company policy of continual product development you are advised to check with your local Palram Industries supplier to ensure that you have obtained the most up to date information.

©1997 Palram Industries Ltd. | SUNTUF is a registered trademark of Palram Industries Ltd.

